

Contact Us

Our offices

Seward Limited (UK)

Technology Centre
Easting Close
Worthing
West Sussex, BN14 8HQ
United Kingdom

Tel: +44 (0)1903 524 600
Email: info@seward.co.uk

Seward Laboratory Systems Inc. (USA)

Sales and Warehouse:
155 Keyland Court
Bohemia, NY 11716, USA

Tel: +1 631 337 1808
Email: info@sewardusa.com

www.seward.co.uk

seward
World leaders in sample preparation

Stomacher® 3500

User Manual

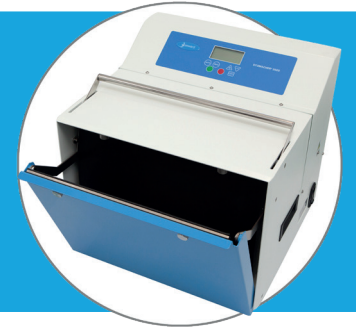

www.seward.co.uk

Thank you for purchasing this Seward product

This manual contains operating instructions for the **Stomacher® 3500**.

The **Seward Stomacher®** was originally developed in conjunction with Unilever's Research Centre at Colworth House; Bedfordshire as a solution to many of the problems previously experienced in microbiological sample preparation.

The **Seward Stomacher®** is a unique homogenising instrument in which the sample is blended within a special disposable bag. The instrument acts on the bag in an action similar to the action of a stomach, hence the name **Stomacher®**.

The instrument is comprised of an electric motor-driven worm gear unit with twin output shafts coupled to flexible crank mechanisms, which in turn operate two reciprocating paddles. An important feature of the system is that the working parts do not come into direct contact with the sample being processed. The main body of the instrument is aluminium alloy, finished with durable hygienic paint; the door and linkage assemblies are stainless steel. All the control functions and displays are ergonomically grouped and conveniently situated.

Seward have continually developed the **Stomacher®** to maintain its position as the market leader ensuring exacting performance, high quality and exceptional reliability.

This manual provides the user with all the information to install, operate and maintain the **Seward Stomacher®**. Please read the manual carefully before using this equipment.

CAUTION: - This equipment should not be used if damaged in any way. If in doubt please contact your local **Seward** authorised service centre.

Should any other questions arise please do not hesitate to contact the **Seward Customer Service Department** on:-

Telephone: +44 (0)1903 524 600

E-mail: info@seward.co.uk

www.seward.co.uk

Stomacher® is a registered Trademark and may not be used without the express permission of **Seward Ltd**.

TABLE OF CONTENTS

1. OPERATION.....	4
1.1 Preparing For Use.....	4
1.2 Processing.....	5
1.3 Paddle Adjustment.....	5
1.4 After Processing.....	5
2. APPLICATION.....	6
2.1 Bag Selection and Filling.....	6
2.2 Speed Selection.....	6
2.3 Control Key Functions.....	7
2.4 Display Icon Functions.....	8
3. INSTRUCTIONS FOR USE.....	9
3.1 Manual operation.....	9
3.2 Automatic operation.....	10
3.3 Storing Processing Programmes.....	10
3.4 Stall Condition.....	11
4. MAINTENANCE.....	12
4.1 Cleaning	12
4.2 Replacing primary Fuses.....	12
4.3 Servicing and Spare Parts.....	12
5. WARRANTY AND SERVICE POLICY.....	13
6. COMPLIANCE.....	13
7. STORAGE AND TRANSPORT.....	13
8. SPECIFICATIONS.....	14

Stomacher® 3500

General layout

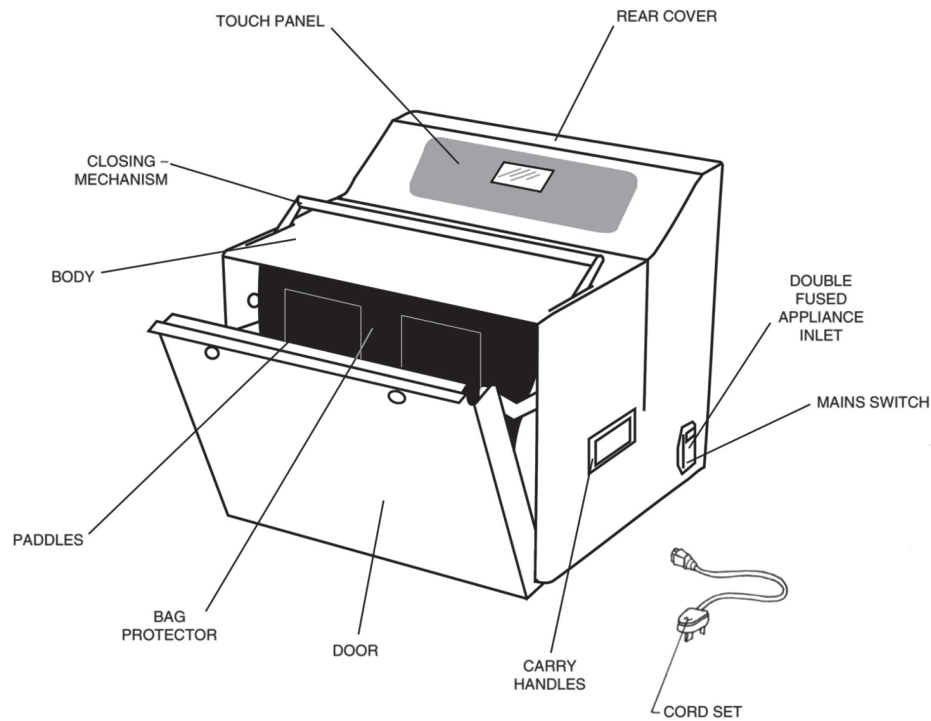

1. OPERATION

1.1 Preparing For Use

Upon receipt of your Seward Stomacher® inspect the shipping carton for any signs of damage. Carefully unpack and inspect the instrument, reporting any obvious damage or missing parts to the supplier/dealer/carrier as appropriate.

The carton should contain the following items: -

1. One **Seward Stomacher®**.
2. Power cord set.
3. Quick start instruction pack including sample bags.

Retain the shipping carton in case of a need to return the instrument or for long term storage.

We have tried to provide the correct power cord for your market area, although if you find that the plug is not compatible with the socket outlet available it will be necessary to obtain a suitable alternative cord set.

CAUTION: - **Seward Stomachers®** are designed to operate in ambient temperatures above 10°C Therefore, if the instrument has been stored or transported at temperatures below 10°C it should be left in an ambient greater than 10°C, for at least two hours prior to use.

CAUTION: - Before connecting the instrument to a power supply, check that the voltage and frequency details shown on the instrument are compatible with your mains electrical supply. The instrument must only be connected to a protectively earthed mains electrical supply. In the event of uncertainty, a competent qualified electrician should be consulted.

CAUTION: - Ensure that the instrument is not positioned directly against a wall or other equipment such that the ventilation slots are obstructed or restricted; we recommend that a minimum of 75mm (3") clear space around the unit is maintained.

CAUTION: - If this equipment is used in a manner not specified by Seward, protection provided by the equipment may be impaired.

Connect the **Seward Stomacher®** to the mains electrical socket using the power cord supplied. Ensure that the door is properly closed with the slotted lower hinge lugs located fully into the pivot points. Operate the power switch, which should illuminate indicating that the instrument is now ready for use.

1.2 Processing

The **Stomacher® 3500** is factory-set with a 20mm paddle clearance between the inner face of the door and the fully extended paddles. Although suited to a wide range of applications these settings are by no means suitable for all sample processing and adjustment may be necessary for your application.

Provision for this adjustment is provided inside the instrument. Since this requires the removal of the rear cover a competent qualified technician should carry out this work.

1.3 Paddle Adjustment

Switch off and disconnect the instrument from the mains electrical supply. Turn the instrument over, suitably supporting it to prevent damage. Remove the rear cover and slacken the socket cap screws holding the motor carriage to the main body via the slotted holes. Do not slacken any of the screws within the carriage assembly or the motor alignment will be lost. Remove the large hexagon headed blanking plug (if fitted) from the rear chassis to access the adjusting screw. Turn the adjusting screw until each paddle just touches the inside face of the door when they are at their maximum forward stroke position, this can be tested by manually rotating the gearbox output shaft.

If the instrument is run briefly the alternate tapping noise of each paddle touching the door should just be audible. Take up any backlash in the adjusting screw and turn the screw back one to one and a quarter turns. This is the minimum clearance setting.

For a greater paddle clearance, each additional backward turn of the adjusting screw increases the clearance by 1.5mm.

When adjustment is complete always re-tighten the socket cap screws, replace the hexagon headed blanking plug where fitted, and replace the rear cover.

The **Stomacher® 3500** is fitted with a neoprene rubber protective lining to the stomaching chamber to prevent any possibility of the bags being trapped behind the paddles, especially when using relatively small sample volumes.

Do not attempt to run the instrument without the protective lining in place

1.4 After Processing

Due to the infinite variety of samples that may be processed in a **Stomacher®** it is not possible to provide definitive procedures for every application, or give any undertaking, implied or otherwise, as to the validity of any method used. **Seward Limited** maintain a library of reference papers covering practical experience with the **Stomacher® system** over many years and these details are available to users upon request.

2. APPLICATION

There are no set rules in the application of the **Stomacher®** instrument and the following is intended as a guide only and not to restrict laboratory technique.

2.1 Bag Selection and Filling

For best results it is recommended that only genuine **Seward Stomacher® Bags** be used. Deep frozen foods should not harm the bags but hard particles such as bone, grit, fruit-stones and seeds may cause puncturing. Where a marginal condition exists or any hazardous material is being blended it is recommended that two bags are used one inside the other.

If required, several bags may be processed simultaneously providing the total volume does not exceed 3500 ml. When doing so, it is recommended that they be layered vertically so that the 'load' is fairly evenly distributed over the paddle faces.

For volumes greater than 3500ml, an alternative **Stomacher®** model should be used.

2.2 Speed Selection

The 150 setting is considered suitable for the vast majority of applications. The 125 setting may be more suitable for delicate work. The 175 setting can provide better agitation when blending predominately liquid substances possibly enabling the processing time to be reduced.

2.3 Control Key Functions

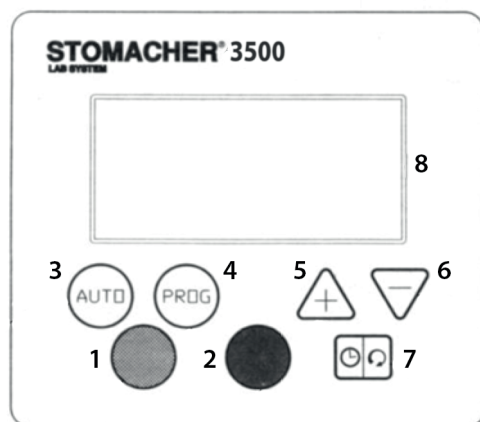

1. START key: -

Starts the instrument when in manual mode and initially in AUTO.

2. STOP key: -

Stops the instrument in either operational mode.

3. AUTO key:-

Toggles the instrument between MANUAL and AUTO operating modes.

4. PROG key: -

Toggles through stored programme selection, P1, P2, P3 and no programme.

5. + (PLUS) key:

Increases the value of the enunciated parameter, i.e. speed / time.

6. - (MINUS) key:-

Decreases the value of the enunciated parameter, i.e. speed / time.

7. SPEED / TIME key: -

Toggles the display enunciator icon between SPEED and TIME displays.

8. Liquid Crystal Display: -

Displays selected function values and status icons.

2.4 Display Icon Functions

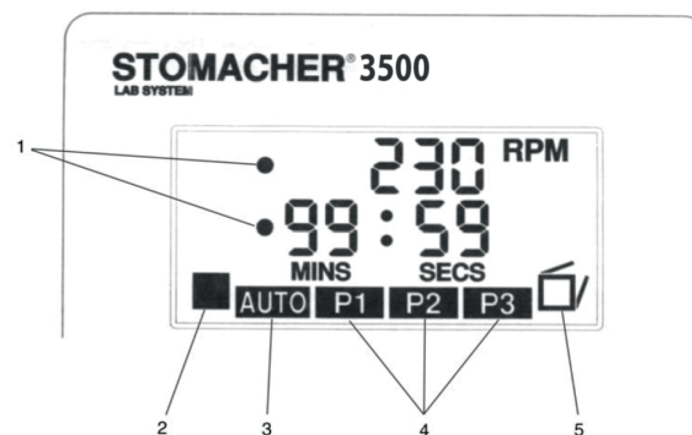

1. ENUNCIATOR icon: -

Continuously indicates whether the speed or time parameter has been selected.

2. STALL CONDITION icon: -

Displayed only when a motor stall condition has occurred.

3. AUTO icon: -

Displayed only when AUTO mode is selected, there is no icon display for MANUAL mode.

4. P1, P2, and P3 icons: -

Displayed individually, when a stored programme is selected.

5. DOOR OPEN icon: -

Displayed only when the door is open.

3. INSTRUCTIONS FOR USE

3.1 Manual Operation

Please note that pressing any control function key is acknowledged by a short tone (0.1 seconds duration) emitted from the instrument's internal sounder.

1. Ensure the POWER rocker switch is in the on (1) position. The green lamp in the switch should be illuminated indicating that power is present and the instrument should also emit a short tone. The display should now indicate the instrument status.
2. Ensure the AUTO icon is **not** displayed. If AUTO is shown, press the AUTO key to revert to MANUAL mode. Similarly, if programmes, P1, P2, or P3 are selected, press PROG repeatedly until no programme is selected.
3. Open the door by raising the lid fully upward and back. This gives access to the paddle compartment. The DOOR OPEN icon will now be displayed.
4. Place the **Stomacher® Bag(s)** into the paddle compartment leaving 50 to 60mm protruding above the bag clamp and close the door thus clamping the bag(s). The DOOR OPEN icon will now be off.
5. The ENUNCIATOR icon indicates that the time parameter has been selected (display defaults to 30 seconds). The time parameter can now be adjusted by pressing the + or – key as required. The setting is variable between 0 seconds and 99 minutes 59 seconds in increments of 1 second. Pressing and releasing the + or – key increments the time by 1 second, holding down the + or – key accelerates the rate of change.
6. Pressing the SPEED / TIME key toggles the ENUNCIATOR icon to indicate that the speed parameter has been selected (display defaults to 150rpm). The speed setting can now be adjusted by pressing the + or – key as required.

The settings available are 75-180rpm in 1rpm increments.

7. Pressing the START key will initiate the stomaching process. The instrument will run at the selected speed and duration. Please note that the time display counts down from the selected time and displays the remaining processing time. The stomaching process continues in normal circumstances until either: -

- **The timed cycle has finished.**
- **The STOP key is pressed.**
- **The door has been opened.**
- **The power has been switched off.**

In all instances the time resets to the selected value.

8. After processing, simply open the door and remove the **Stomacher® Bag(s)**. The instrument is ready for processing the next sample.

WARNING: - Opening the door during the operating cycle causes the instrument to stop. This however, **must not** be considered the normal method for stopping the instrument.

3.2 Automatic Operation

If a number of samples are to be processed under the same conditions, i.e. speed / time values, then you may prefer to select the AUTO mode. When in AUTO the stomaching process is initiated by the opening and closing of the door between sample loadings.

1. Select speed / time values as previously described in 3.1.6.
2. Press the AUTO key, displaying the AUTO Icon.
3. Load the charged **Stomacher® Bag(s)** as previously described in 3.1.4.
4. Closing the door will initiate the stomaching process. The instrument will run at the selected speed and duration. Please note that the time display counts down from the selected time and displays the remaining processing time. The stomaching process continues in normal circumstances until either: -
 - The timed cycle has finished.
 - The STOP key is pressed.
 - The door has been opened.
 - The power has been switched off.

In all instances the time resets to the selected value.

5. When the processing is completed simply open the door, remove the processed sample and place the next sample into the instrument. Close the door and processing will commence automatically.

3.3 Storing Processing Programmes

It is possible to store up to three combinations of speed / time values as programmes within the instrument's memory. This enables the most frequently used or specific processing parameters to be recalled easily and efficiently.

To store or change a programme: -

1. Pressing and releasing the PROG key toggles through the three programme selections denoted by the P1, P2 and P3 icons and returns to manual (no PROG con). Please note these initially display memory-stored default values. Press and release the PROG key at the desired programme number.
2. Adjust the speed / time values as described previously in 3.1.6.
3. Simultaneously press and hold down the AUTO key and PROG Key for at least 2 seconds. This is acknowledged by a longer tone (0.5 seconds' duration). The displayed speed / time values are stored in the memory.

3.3 Using Stored Processing Programmes

In Manual mode: -

1. Press and release the PROG key to select the desired programme. Either the P1, P2 or P3 icon should now be present on the display.
2. Load the **Stomacher® Bag(s)** as previously described.
3. Pressing the START key will initiate the stomaching process as previously described.
4. After processing, simply open the door and remove the **Stomacher® Bag(s)**. The instrument is ready for processing the next sample.

In Auto mode: -

1. Press and release the PROG key to select the desired programme. Either the P1, P2 or P3 icon should now be present on the display.
2. Press the AUTO key, displaying the AUTO icon.
3. Load the **Stomacher® Bag(s)** as previously described.
4. Closing the door will initiate the stomaching process as previously described.
5. When the processing is completed simply open the door, remove the processed sample and place the next sample into the instrument. Close the door and processing will commence automatically.

3.4 Stall Condition

The drive controller has a factory-set electrical current limiting device to protect the motor in the event of a stall condition occurring. In the event of a stall condition the STALL icon will be displayed on the control panel and the instrument will stop. This condition may simply occur due to overloading the paddles in which case the sample size should be reduced.

WARNING:- Opening the door during the operating cycle causes the instrument to stop. However, this **must not** be considered as the normal method for stopping the instrument.

If events B, C or D occur the timer automatically resets to zero.

7. After processing, simply open the door and remove the bag(s). The instrument is immediately ready for processing the next sample.

NOTE: -

A motor electrical current limiting device is incorporated into the control circuit. Upon initial start-up, a short time may elapse before the motor builds up torque and runs normally. This condition is more likely to prevail under the following circumstances:

- i) Upon initial start-up following a period of transportation or storage
- ii) The instrument has been stored in a cold environment (less than 10°C allowing the rubber connectors to become stiff).

For condition (i) run the instrument for 5-10 minutes, preferably with a number of stop-start cycles. For condition (ii) allow the instrument to stand in a warm

environment, followed by a short period of running with stop-start cycles.

4. MAINTENANCE

4.1 Cleaning

The instrument should be kept externally clean by wiping over periodically with a cloth dampened with mild liquid detergent. **Do not** use any solvent-based cleaning agents, as they will damage the paint finish. First switch the instrument off and disconnect from the mains electrical supply before wiping down all the surfaces including the control panel.

CAUTION: - Ensure the equipment is switched **off** and unplugged from the mains electrical supply before cleaning near any electrical components.

To facilitate cleaning the processing chamber, the door hinge lugs are open slotted to enable the door to be lifted from the lower pivot pins. To do this open the door in the normal way by lifting the lid fully upward and back then pull the door sharply upwards. In the **Stomacher® 3500** the black neoprene sheet should be removed first by unscrewing the knurled thumbscrews.

A small handled brush may be helpful for cleaning. It is recommended this procedure be carried out immediately in the event of any spillage. Refitting of the door is the reversal of the above procedure; ensure the door hinge lugs are fully engaged on both sides before commencing use.

4.2 Replacing Primary Fuses

The primary fuses can only be removed with the aid of a tool, typically a screwdriver, since they are not considered operative replaceable. In the event of a fuse failure we recommend the equipment and mains electrical supply is checked by a competent qualified electrician.

WARNING: - When replacing fuses ensure they are replaced with fuses of the same rating and specification, refer to the appropriate model specification section of this manual. Please contact **Seward Technical Service** if in doubt.

4.3 Servicing and Spare Parts

Suitably qualified persons should only carry out internal servicing and maintenance. A Maintenance Manual is available giving full details of servicing and repair procedures, wiring diagrams, parts identification and general assembly drawings. We recommend as a matter of routine that the instrument is inspected and serviced at least every six months or sooner if extensively used.

CAUTION: - This equipment should not be used if damaged in any way. If in doubt please contact your local **Seward Ltd** authorised service centre.

5. WARRANTY AND SERVICE POLICY

All **Seward Stomachers®** are protected by a 36-month warranty covering faulty workmanship and materials. In the event of a fault developing within this period please contact **Seward Customer Service** who will organise the collection/return of the instrument for warranty repair and/or replacement at Seward's discretion.

The warranty is void if the instrument has been damaged as a result of unauthorised service, modification or subject to neglect, misuse, and accident, improper installation or operation.

6. COMPLIANCE

Seward Stomachers® are designed and manufactured to conform to the following standards: -

- IEC 61010-1 : 1990 Safety Requirements for Electrical Equipment for Measurement, Control and Laboratory Use.
- UL 3101 - 1 : 1993 Electrical Equipment for Laboratory Use General Requirements
- This equipment complies with the essential requirements of the European Council Directive 2006/42/CE relating to EMC and carries the CE mark.

7. STORAGE AND TRANSPORT

Recommended storage and transport conditions are:-

Ambient Temperature Range -20 to + 50°C

Relative Humidity Range 10 - 90%

Seward Stomachers® should ideally be stored in a clean environment and for long periods of storage it should be re-packed in the original packaging.

Seward Stomachers® should be transported in the original packaging.

8. STOMACHER® 3500 - SPECIFICATIONS

Model	American and Japanese Product	EU Product
Cat No.	3500/000/AM	3500/000/EU
Dimensions	480mm W x 480mm D x 445mm H (unpacked)	480mm W x 480mm D x 445mm H (unpacked)
Weight	36kg (unpacked)	36kg (unpacked)
Supply Voltage	100-120V	220-250V
Supply Frequency	50-60Hz	50-60Hz
Mains Inlet Fuses*	T2.0A 250V 5x20mm, breaking capacity: 100A @ 250V	T1.0A 250V 5x20mm, breaking capacity: 35A @ 250V
Transformer Fuse*	T250mA 250V 5x20mm, breaking capacity: 35A @ 250V	T250mA 250V 5x20mm, breaking capacity: 35A @ 250V
PCB Fuse*	F2.5A 250V 5x20mm, breaking capacity: 100A @ 250V	F2.5A 250V 5x20mm, breaking capacity: 100A @ 250V
Insulation	Class 1 (Earthed)	Class 1 (Earthed)
Installation	Over Voltage Category II	Over Voltage Category II
Pollution	Pollution Degree 2	Pollution Degree 2
Duty Cycle	Continuous	Continuous
Rated Load	120W	120W
Disposable Bag	380mm x 508mm	380mm x 508mm
Minimum Recommended Capacity	1000ml	1000ml
Maximum Recommended Capacity	3500ml	3500ml
Maximum Recommended Sample Temperature	60°C	60°C
Recommended Operating Ambient Temperature - Range	10-35°C	10-35°C
Recommended Operating Relative Humidity Range	10-89%	10-89%
Fixed Timer Settings	1second to 99 minutes 59 seconds (±5%)	1second to 99 minutes 59 seconds (±5%)
No Load Paddle Speeds (@ nominal 20°C)	75 - 180 rpm (±5%) in 5 second increments	75 - 180 rpm (±5%) in 5 second increments
Paddle Clearance	0-20mm	0-20mm
Programs Preloaded	P1: 125 rpm, 30 seconds (±5%) P2: 150 rpm, 45 seconds (±5%) P3: 175 rpm, 1 minute (±5%)	P1: 125 rpm, 30 seconds (±5%) P2: 150 rpm, 45 seconds (±5%) P3: 175 rpm, 1 minute (±5%)

* Only these or equivalent UL-approved fuses should be used